

Freestanding French Door Refrigerator, 79cm, 487L

Series 7 | Contemporary

Stainless Steel | French hinge



Designed for those who need plenty of flexible space for their cold and frozen food storage.

- ActiveSmart™ technology helps keep food fresher for longer by constantly maintaining the ideal temperature.
- Spacious bottom freezer with full extension drawer gives easy access to frozen goods.

DIMENSIONS

Height	1715 mm
Width	790 mm
Depth	695 mm

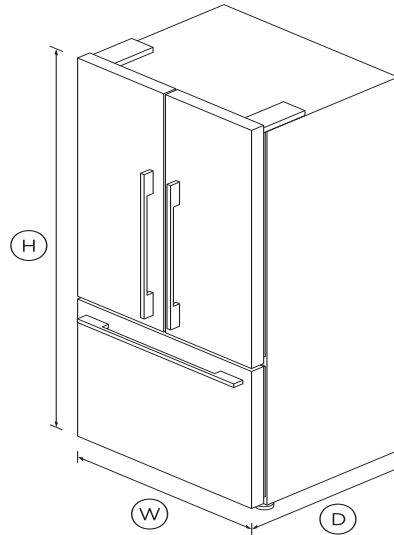

FEATURES & BENEFITS

ActiveSmart™ Foodcare

Every time you open your refrigerator, the temperature around your food changes. ActiveSmart™ foodcare adjusts airflow to create a stable temperature, helping your food stay fresher for longer.

Simple storage

This refrigerator is designed to make it simple for you to store, access and remove food. Storage bins give you full access inside when they're pulled open and can be easily removed to clean.

Our flexible shelving also gives you more storage options.

Humidity control

Your fruit and veges need different environments. The humidity control slides in each storage bin create a microclimate that helps keep food fresher for longer.

Easy cleaning

No more permanent dirty marks with our EZKleen feature for stainless steel refrigerators. Anti-fingerprint coating means you simply wipe clean any marks. Spill-safe secure glass shelves easily capture any drips or leaks.

Design quality

Our refrigerators are designed and built using quality materials. We use real stainless steel, and solid glass for shelving.

Clever energy

Your refrigerator adapts to daily use by cooling and defrosting only when needed. This means it uses only the energy it needs without compromising on food care.

Complementary design

With their premium handle styling and stainless steel finish, our refrigerators are designed to match the rest of Fisher & Paykel's kitchen appliance family.

SPECIFICATIONS

Accessories (sold separately)

Stainless steel surround kit	Part number 25849
------------------------------	-------------------

Capacity

Freezer	142L
Refrigerator	345L
Total net volume	487L

Consumption

Energy consumption	361kWh/year
Energy rating	F

Height	1715 mm
Minimum air clearance - each	20 mm
Minimum air clearance - on top	50 mm
Width	790 mm

and specifications may change at any time. You should therefore check with Fisher & Paykel's Customer Care Centre to ensure this page correctly describes the model currently available. © Fisher & Paykel Appliances Ltd 2020

Freezer features

Bottle chill	•
Door alarm	•
Fast freeze	•
Ice bin and scoop	•
Ice trays	2
Large plastic bin	•
Small plastic bins	2

Refrigerator features

Adjustable door shelves	6
Adjustable glass shelves	3
Covered door shelves	2
Door alarm	•
Front levelling feet	•
Fruit and vegetable bins	2
Full extension runners	•
Full width door shelves	2
LED lighting	•
Rear rollers	•
Single bottle holders	4
SmartTouch control panel	•
Stackable bottle holders	4
Ultra slim water dispenser	•

Performance

ActiveSmart™ Foodcare	•
ActiveSmart™ technology	•
Adaptive defrost	•
Frost free	•
Frost free freezer	•
Humidity control system	•
Inverter controlled compressor	•
Noise emissions	42dBA
Noise emissions class	D
R600a refrigerant	•
Sabbath mode	•

Warranty

Parts and labour	5 years
Sealed system parts only	5 years

Power Requirements

Supply voltage	220 - 240V
----------------	-------------------

SKU	26024
-----	--------------

Product dimensions

Depth	695 mm
-------	---------------

TEST The product dimensions and specifications in this page apply to the specific product and model. Under our policy of continuous improvement, these dimensions

Other product downloads available at fisherpaykel.com



User Guide



Service & Warranty Booklet



Installation Guide



Installation Guide (Surround kit)



Resources (zip)



A PEACE OF MIND SALE

24 Hours 7 Days a Week Customer Support

T 08000 886 605 **W**www.fisherpaykel.com