

Classic 60 Dual Fuel Professional+ 60 Dual Fuel

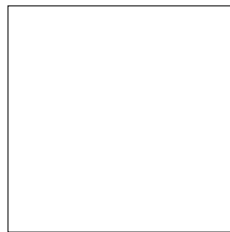

User Guide

Installation & Service Instructions

RANGEmaster

U111324-03

Contents

1. Before You Start...	1	7. Troubleshooting	18
General instructions	1	8. Installation	20
Installation and Maintenance	1	Dear Installer	20
Peculiar smells	1	Safety Requirements and Regulations	20
Ventilation	1	Location of Cooker	20
Personal Safety	1	Positioning the Cooker	21
Cooker Care	2	General instructions	21
Cleaning	2	Installation of the Cooker	21
If a Fault Occurs	2	Moving the Cooker	22
2. Cooker Overview	3	Electrical Connection	24
Hotplate Burners	4	Anti-tilting kit	25
The Griddle	5	Adjusting the feet	25
Oven Accessories	6	Final Checks	25
3. Multifunction Modes	8	Customer Care	25
4. Clock	10	9. Conversion to LP Gas	26
5. Cooking Tips	13	Changing injectors	26
6. Cleaning Your Cooker	14	Pressure Testing	27
Hotplate Burners	14	10. Circuit Diagram	28
The Griddle	14	11. Technical Data	29
Grill	14		
Control Panel and Doors	15		
Oven Door Panel	15		
Ovens	15		

1. Before You Start...

Thank you for buying this cooker. It should give you many years of trouble-free cooking if installed and operated correctly. It is important that you read this section before you start, particularly if you have not used a gas cooker before.

⚠ This appliance is designed for domestic cooking only. Using it for any other purpose could invalidate any warranty or liability claim. In particular, the oven should NOT be used for heating the kitchen – besides invalidating claims this wastes fuel and may overheat the control knobs.

General instructions

After removing the packaging material from the appliance and its accessories, ensure that the appliance is not damaged. If you suspect any damage, do not use it and contact an authorised service person or qualified technician immediately.

- Make sure that there are no flammable or combustible materials in the close vicinity, such as curtains, oil, cloth etc. which may catch fire.
- The worktop and furniture surrounding the appliance must be made of materials resistant to temperatures above 100°C.
- The appliance should not be installed next to a dishwasher, fridge, freezer, washing machine or clothes dryer.
- The appliance can be placed close to other furniture on condition that, in the area where the appliance is set up, the furniture's height does not exceed the height of the cooktop.

Installation and Maintenance

In the UK, the cooker must be installed by a Gas Safe registered engineer. All installations must be in accordance with the relevant instructions in this booklet, with the relevant national and local regulations, and with the local gas and electricity supply companies' requirements.

Make sure that the gas supply is turned on and that the cooker is wired in and switched on (the cooker needs electricity).

It is recommended that this appliance is serviced annually.

Only a qualified service engineer should service the cooker, and only approved spare parts should be used.

Always allow the cooker to cool and then switch it off at the mains before cleaning or carrying out any maintenance work, unless specified otherwise in this guide.

⚠ Stabilizing brackets must be installed in order to prevent tipping of the appliance.

Peculiar smells

When you first use your cooker it may give off a slight odour. This should stop after a little use.

Before using for the first time, make sure that all packing materials have been removed and then, to dispel manufacturing odours, turn the ovens to maximum temperature and run for 45 minutes.

Make sure the room is well ventilated to the outside (see 'Ventilation' below). People with respiratory or allergy problems should vacate the area for this brief period.

Ventilation

The use of a cooking appliance results in the production of heat and moisture in the room in which it is installed. Therefore, ensure that the kitchen is well ventilated: keep natural ventilation holes open or install a powered cooker hood that vents outside. If you have several burners on, or use the cooker for a long time, open a window or turn on an extractor fan.

Personal Safety

⚠ Do not modify this appliance.

⚠ This appliance is not intended for use by persons (including children) with reduced physical, sensory or mental capabilities, or lack of experience and knowledge, unless they have been given supervision or instruction concerning use of the appliance by a person responsible for their safety.

⚠ Children or infirm persons should be supervised to ensure that they do not play with the appliance.

⚠ CAUTION: A long term cooking process has to be supervised from time to time. A short term cooking process has to be supervised continuously.

⚠ Danger of fire: DO NOT store items on the cooking surfaces.

⚠ Accessible parts will become hot during use and will retain heat even after you have stopped cooking. Keep babies and children away from the cooker and never wear loose-fitting or hanging clothes while the appliance is in use.

⚠ DO NOT use a steam cleaner to clean the cooker.

Always be certain that the controls are in the OFF position when the oven is not in use, and before attempting to clean the cooker.

⚠ When the oven is on, DO NOT leave the oven door open for longer than necessary, otherwise the control knobs may become very hot.

⚠ While the oven door is open do not let children climb on the door or sit on it.

⚠ DO NOT spray aerosols in the vicinity of the cooker while it is on.

Use dry oven gloves when applicable – using damp gloves might result in steam burns when you touch a hot surface. Do not use a towel or other bulky cloth in place of a glove – it might catch fire if brought into contact with a hot surface.

⚠ NEVER operate the cooker with wet hands.

⚠ DO NOT use aluminium foil to cover shelves, linings or the oven roof.

⚠ NEVER heat unopened food containers. Pressure build up may make the containers burst and cause injury.

⚠ DO NOT use unstable saucepans. Always ensure that you position the handles away from the edge of the hotplate.

Never leave the hotplate unattended at high heat settings. Pans boiling over can cause smoking, and greasy spills may catch on fire. Use a deep fat thermometer whenever possible to prevent fat overheating beyond the smoking point.

⚠ NEVER leave a chip pan unattended. Always heat fat slowly, and watch as it heats. Deep fry pans should be only one third full of fat. Filling the pan too full of fat can cause spill over when food is added. If you use a combination of oils or fats in frying, stir them together before heating, or as the fats melt.

Foods for frying should be as dry as possible. Frost on frozen foods or moisture on fresh foods can cause hot fat to bubble up and over the sides of the pan. Carefully watch for spills or overheating of foods when frying at high or medium high temperatures. Never try to move a pan of hot fat, especially a deep fat fryer. Wait until the fat is cool.

Do not use the top of the flue (the slot along the back of the cooker) for warming plates, dishes, drying tea towels or softening butter.

⚠ DO NOT use water on grease fires and never pick up a flaming pan. Turn off the controls and then smother a flaming pan on a surface unit by covering the pan completely with a well fitting lid or baking tray. If available, use a multipurpose dry chemical or foam-type fire extinguisher.

Cooking high moisture content foods can create a 'steam burst' when the oven door is opened. When opening the oven stand well back and allow any steam to disperse.

Always keep combustible materials, e.g. curtains, and flammable liquids a safe distance away from your cooker.

Take care that no water seeps into the appliance.

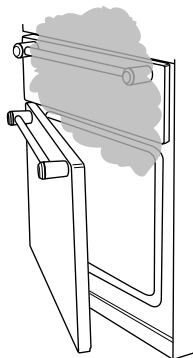

⚠ Do not attempt to lift or move the appliance by pulling the door handles.

⚠ NEVER allow anyone to climb or stand on the hob.

⚠ The appliance is not intended to be operated by means of external timer or separated remote control system.

Only certain types of glass, glass-ceramic, earthenware or other glazed containers are suitable for hotplate cooking; others may break because of the sudden change in temperature.

Cooker Care

As steam can condense to water droplets on the cool outer trim of the oven, it may be necessary during cooking to wipe away any moisture with a soft cloth. This will also help to prevent soiling and discolouration of the oven exterior by cooking vapours.

Cleaning

⚠ DO NOT use abrasive cleaners/pads, oven aerosols/pads or stain removers on the surface.

In the interests of hygiene and safety, the cooker should be kept clean at all times as a build up in fats and other food stuff could result in a fire.

Clean only the parts listed in this guide.

Clean with caution. If a wet sponge or cloth is used to wipe spills on a hot surface, be careful to avoid steam burns. Some cleansers can produce noxious fumes if applied to a hot surface.

If a Fault Occurs

If your appliance develops a fault and you are unable to solve the problem, contact one of our service centres on the below numbers:

UK Service Centre Tel: 0844 847 6711.

Republic of Ireland Service Centre Tel: 051 302 333

2. Cooker Overview

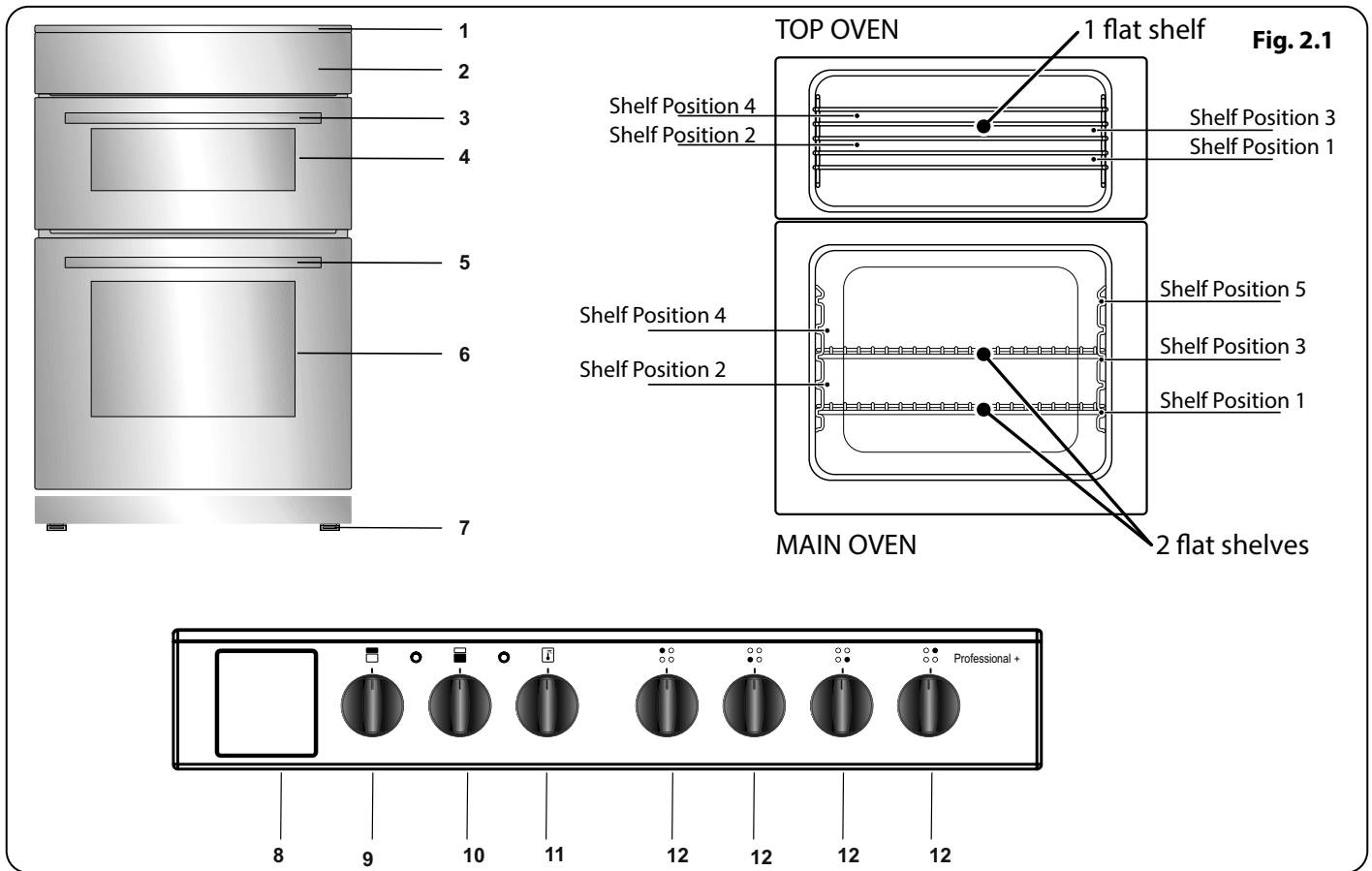

The 60cm cooker (**Fig. 2.1**) has the following features:

1. Cooktop
2. Control Panel
3. Top Oven Door Handle
4. Top Oven Door
5. Main Oven Door Handle
6. Main Oven Door
7. Adjustable Feet
8. Timer
9. Top Oven Control Knob
10. Main Oven Control Knob
11. Main Oven Thermostat Knob
12. Hob Control Knob

Fig. 2.2

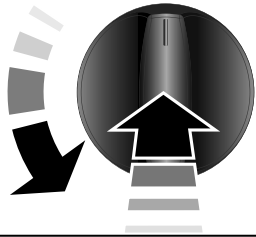

Fig. 2.3

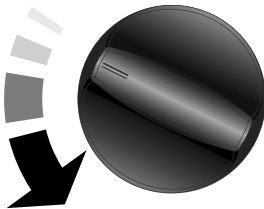

Fig. 2.4

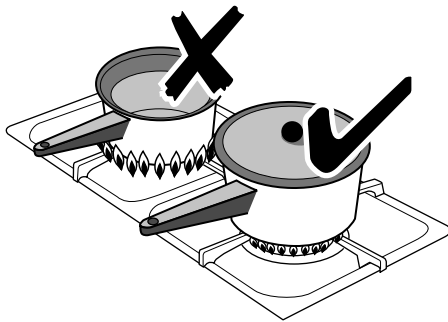

Fig. 2.5

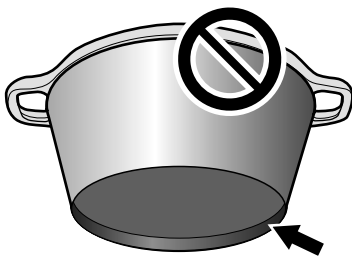

Fig. 2.6

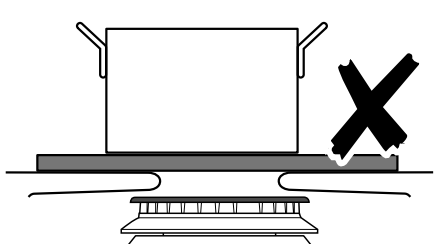
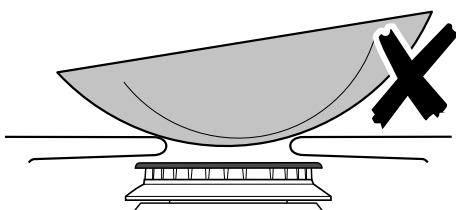

Fig. 2.7



Hotplate Burners

The drawing by each of the knobs indicates which burner that knob controls.

Hobs equipped with a flame failure device provide security in case of an accidentally extinguished flame. For this reason, during ignition, keep the knob pressed until you see stable flames.

To ignite a hotplate burner push in and turn the associated control knob counterclockwise to the high position as indicated by the large flame symbol (🔥), (Fig. 2.2). Hold down the control for approximately 10 to 15 seconds after the burner has lit. Releasing the control too soon will extinguish the flame.

If such a case occurs, the device will block the burners gas lines and will avoid any accumulation of unburned gas. Turn the control knob to the off (0) position, wait 90 seconds before re-igniting an extinguished gas burner.

Sparks are generated as long as the control knob is held in.

Adjust the flame height to suit by turning the knob counterclockwise (Fig. 2.3).

⚠ DO NOT operate the burners between the max (🔥) and off (0) positions.

If a burner flame goes out, turn off the control knob and leave it for 90 seconds before relighting it.

Make sure that the flames are under the pans. Using a lid will help the contents boil more quickly (Fig. 2.4).

Large pans should be spaced well apart.

Pans and kettles with concave bases or down-turned base rims should not be used (Fig. 2.5).

Simmering aids, such as asbestos or mesh mats, are **NOT** recommended (Fig. 2.6). They will reduce burner performance and could damage the pan supports.

You should also avoid using unstable and misshapen pans that may tilt easily, and pans with a very small base diameter, e.g. milk pans, single egg poachers (Fig. 2.7).

DO NOT use cooking vessels on the hotplate that overlap the edges.

To obtain maximum performance from the main burners, we suggest you use pots with the following flat bottom diameters. Using pots smaller than the minimum dimensions shown below will cause energy loss.

Burners	Diameter
Rapid / Wok Burner	22-26 cm
Semi-rapid Burner	14-22 cm
Auxiliary Burner	12-18 cm

The Griddle

The griddle is intended for use on the right of the hob, sitting on the smaller (1kW) and medium (1.7kW) burners (**Fig. 2.8**). It is designed for cooking food on directly. **DO NOT** use pans of any kind on it. The griddle surface is non-stick and metal cooking utensils (e.g. spatulas) will damage the surface. Use heat resistant plastic or wooden utensils.

⚠ DO NOT put it crossways – it will not fit properly and will be unstable (Fig. 2.9).

⚠ DO NOT put it on any other burner – it is not designed to fit on any of the other pan supports.

Position the griddle over the hotplate burners resting on the pan support. Check that it is securely located.

The griddle can be lightly brushed with cooking oil before use. Light the hotplate burners. Adjust the flame heights to suit.

Preheat the griddle for a **maximum of 5 minutes** with the larger burner at 50% and smaller burner at 100% before adding food. Leaving it longer may cause damage. Turn the control knobs towards the low position, marked with the small flame symbol, to reduce the burner flames.

⚠ Always leave space around the griddle for the gases to escape.

⚠ NEVER fit two griddles side by side.

After cooking, allow the griddle to cool before cleaning.

Preheating

We recommend you preheat the oven for 10 minutes before use. For recipes needing high temperatures, such as bread, pastries, scones or soufflés, best results are achieved if the oven is preheated first. For best results when cooking from frozen or cooking chilled ready meals, always preheat the oven first.

Cooking

- Ensure that food is placed centrally on the shelf and that there is sufficient room around the baking tray / dish to allow for maximum circulation.
- Stand dishes on a suitably sized baking tray on the shelf to prevent spillage onto the oven base and to help reduce the amount of cleaning required.
- The material and finish of the baking tray and dishes used will affect base browning. Enamel, dark, heavy or nonstick utensils increase base browning. Shiny aluminium or polished steel trays reflect the heat away and reduce base browning.
- When cooking more than one dish in the oven, place dishes centrally on different shelves rather than cluster several dishes on one shelf. This will allow the heat to circulate freely for the best cooking results.

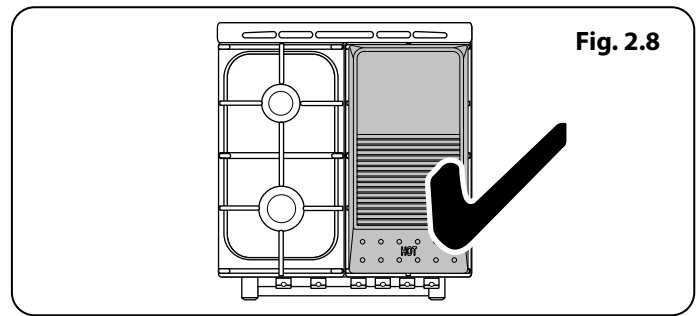

Fig. 2.8

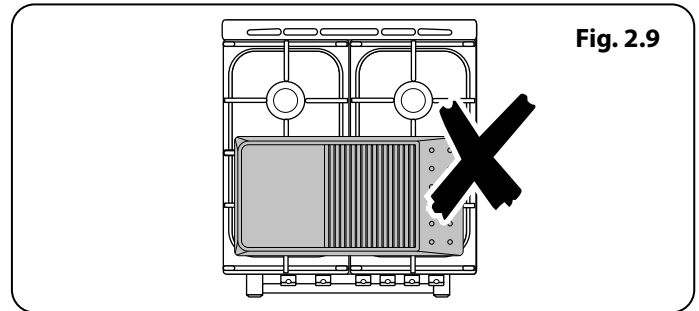

Fig. 2.9

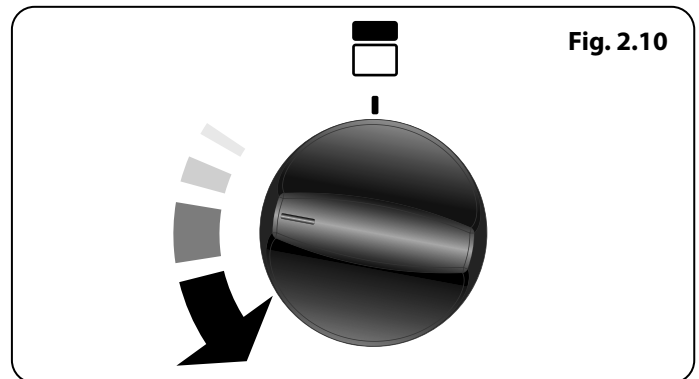

Fig. 2.10

- If you are cooking more than one tray of similar items, for example cakes or biscuits, swap the trays during cooking or remove the top tray when the food on it is cooked and move the lower tray to the higher shelf to finish cooking.
- **DO NOT** place baking trays directly on the oven base as it interferes with the oven air circulation and can lead to base burning. Use the lower shelf position.

'S' (Slow) Cooking Function

Both ovens feature an 'S' setting. This is a low temperature setting for cooking food over a long period. The oven centre is set at 120°C. The 'S' setting can also be used for keeping food warm.

Oven Accessories

The Grill Pan and Handle Set (Fig. 2.11) (Fig. 2.12)

⚠ Warning: The top oven door must be fully open when this function is selected.

The grill pan set is best used for grilling steaks and similar foods.

⚠ WARNING: The grill pan has a detachable handle. Make sure when using the grill pan handle that it is centralised and secure, as shown in the figure.

⚠ Do not leave the handle in position when grilling.

Top Oven Shelves (Fig. 2.13)

Clean the accessories thoroughly with warm water, detergent and a soft clean cloth on first use.

- Insert the accessory to the correct position inside the oven.
- Take care removing cookware and/or accessories out of the oven. Hot meals or accessories can cause burns.
- The accessories may deform with heat. Once they have cooled down, they will recover their original appearance and performance.
- Trays and wire grids can be positioned on any level from 1 to 4.

Please note: Level is 3 recommended for grill cooking.

Bottom Oven Shelves (Fig. 2.14)

Clean the accessories thoroughly with warm water, detergent and a soft clean cloth on first use.

Insert the accessory to the correct position inside the oven.

- Allow at least a 1 cm space between the fan cover and accessories.
- Take care removing cookware and/or accessories out of the oven. Hot meals or accessories can cause burns.
- The accessories may deform with heat. Once they have cooled down, they will recover their original appearance and performance.
- Trays and wire grids can be positioned on any level from 1 to 5.
- Level 3 is recommended for single level cooking.

The Wire Grid for Deep Trays (Fig. 2.15)

Make sure the wire grid is correctly placed within a deep tray. It is recommended to use this accessory for grilling steaks, meatballs and similar food.

The Deep Tray (Fig. 2.16)

The deep tray is best used for cooking stews.

Put the tray into any rack and push it to the end to make sure it is placed correctly.

The Wire Grid (Fig. 2.17)

The wire grid is best used for grilling or for processing food in oven-friendly containers.

⚠ WARNING Place the grid to any corresponding rack in the oven cavity correctly and push it to the end (Fig. 2.18).

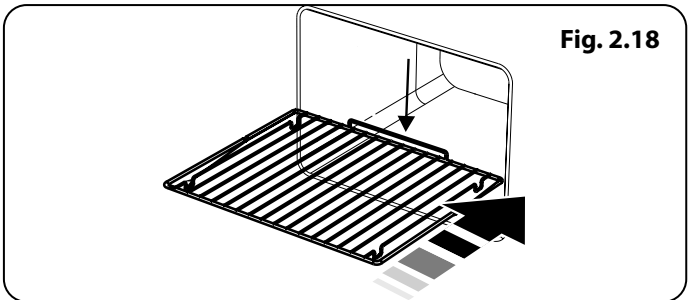
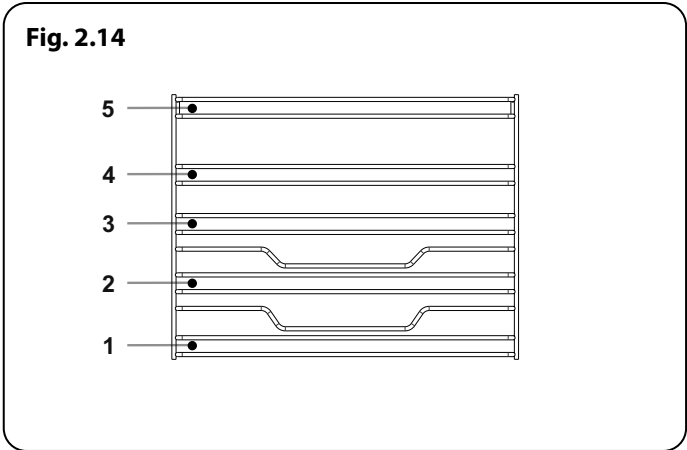
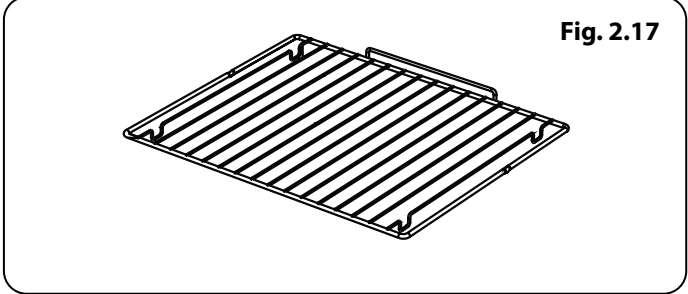
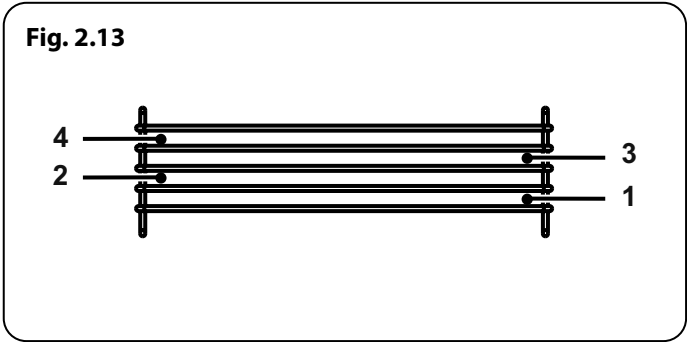
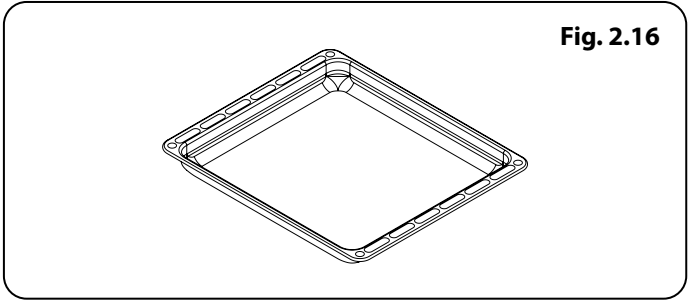
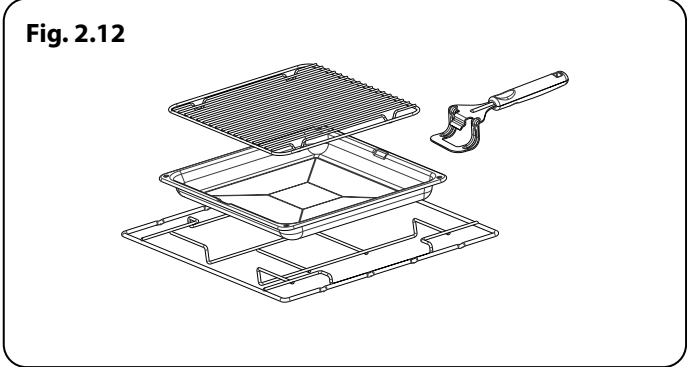
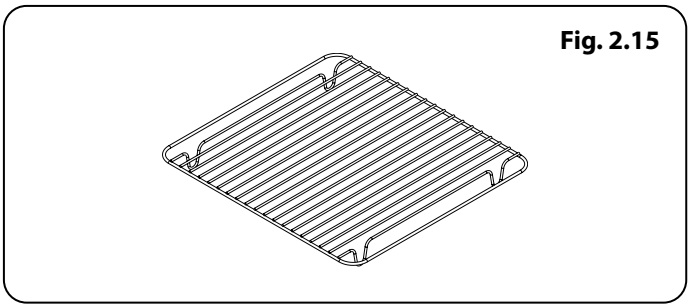
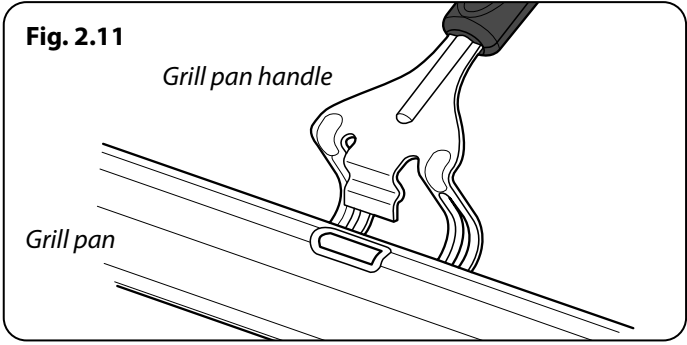

3. Multifunction Modes

* The functions available on your oven may differ from those listed below depending on the model purchased.

Main Oven Control knobs

Main Oven Symbols	Key
	Off
	Defrost
	Fan Oven
	Conventional Oven
	Fan assisted
	Full Grill
	Full Grill and Fan

Main Oven Functions

Defrost



Switch on the **Defrost** function using the main oven function control knob.

The oven's warning lights will switch on, and the fan will start operating. To use the defrost function, place your frozen food on a shelf in the middle of the oven. It is recommended that you put an oven tray under the defrosting food to catch accumulated water due to melting ice. This function will not cook or bake your food, it will only help to defrost it.

Fan Oven



Switch on the **Fan oven** function using the main oven function control knob. The oven's thermostat and warning lights will switch on, and the ring

heating element and fan will start operating. The temperature can be adjusted using the main oven function control knob. The turbo function evenly disperses the heat in the oven so all food on all racks will cook evenly. It is recommended that you preheat the oven for 10 minutes.

Conventional Oven (Top and Base Heat)



Switch on the **Conventional Oven** function using the main oven function control knob.

The oven's thermostat and warning lights will switch on, and the lower and upper heating elements will start operating. The temperature can be adjusted using the main oven function control knob.

The static cooking function emits heat, ensuring even cooking of food. This is ideal for making pastries, cakes, baked pasta, lasagne and pizza. Preheating the oven for 10 minutes is recommended and it is best to cook on only one shelf at a time in this function.

Fan assisted:



Switch on the **Fan assisted** function using the main oven control knob. The oven's thermostat and warning lights will switch on, and the upper and

lower heating elements and fan will start operating. The temperature can be adjusted using the main oven thermostat knob. Cooking is carried out by the lower and upper heating elements within the oven while the fan provides air circulation, dispersing the heat and giving the food a slightly grilled effect. It is recommended you preheat the oven for 10 minutes.

Full Grill



Switch on the **Full Grill** function using the main oven control knob. The oven's thermostat and warning lights will switch on, and the grill heating element

will start operating. The temperature can be adjusted using the main oven thermostat knob. This function is used for grilling and toasting food. Use the upper shelves of the oven. Lightly brush the wire grid with oil to stop food sticking and place food in the centre of the grid. Always place a tray beneath the food to catch any drips of oil or fat. It is recommended that you leave the grill to preheat for 10 minutes.

Warning: When grilling, the oven door must be closed and the oven temperature should be adjusted to 200°C.

Full Grill and Fan







Switch on the **Full Grill and Fan** function using the main oven control knob. The oven's thermostat and warning lights will switch on, and the grill heating

element and fan will start operating. The temperature can be adjusted using the main oven thermostat knob. This function is ideal for thicker foods. When grilling, use the upper shelves of the oven. Lightly brush the wire grid with oil to stop food sticking and place food in the centre of the grid. Always place a tray beneath the food to catch any drips of oil or fat.

Warning: When grilling, the oven door must be closed and the oven temperature should be adjusted to 200°C.

Top Oven Control knobs

Top Oven Symbols	Key
	Off
	Conventional Oven
	Browning Element
	Half Grill
	Full Grill

Top Oven Functions

*The functions available on your oven may differ from those listed below depending on the model purchased.

Conventional Oven (Top and Base Heat)



Switch on the **Conventional Oven** function using the top oven function control knob.

The oven thermostat and warning lights will illuminate, and the upper and lower heating elements will switch on. The temperature can be adjusted using the top oven function control knob.

The heat generated by the upper and lower heating elements ensures that food is cooked evenly. You will find this setting ideal for cooking cakes, baked pasta, lasagne, and pizza. We recommend that the oven is preheated for 10 minutes before use and that you cook on one rack at a time.

Browning Element



Switch on the **Browning** function using the top oven function control knob. The oven thermostat and warning lights will illuminate, and the upper heating element will switch on. The temperature setting will set to the highest level for this function. The UPPER heating function is ideal for heating food or for frying the top of food that has already been cooked, as the heat radiates from the upper heating element closest to the top of the food.

Half Grill:



Switch on the **half grill** function using the top oven function control knob. The oven thermostat and warning lights will illuminate, and the grill heating element will switch on. Use this function for grilling. When you have finished grilling, switch the top oven off. Keep children away from the oven during grilling and until it has fully cooled after use.

⚠ Warning: The top oven door must be fully open when this function is selected.

Full Grill



Switch on the **full grill** function using the function selector knob. The oven thermostat and warning lights will illuminate, and the grill and upper heating elements will switch on. Use this function for wide area grilling. When you have finished grilling, switch the top oven off. Keep children away from the oven during grilling and until the oven has fully cooled after use.

⚠ Warning: The top oven door must be fully open when this function is selected.

4. Clock

The time must be set before you start using the oven. Following the power connection, the symbol "A" and "00:00" or "12:00" will flash on the display.

Fig. 4.1

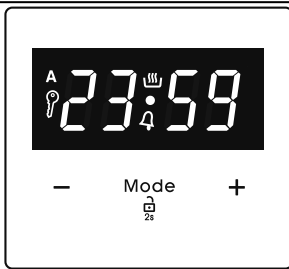

Function	Description
A	Auto Cooking
	Manual Cooking
	Key Lock
	Minute Minder
Mode	Mode Function
-	Decrease Timer
+	Increase Timer
23 59	Timer Display

Setting the time The clock must be set to the time of day before the oven will work

Step. 1

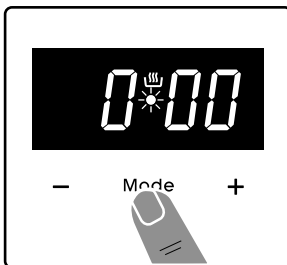

Step. 2

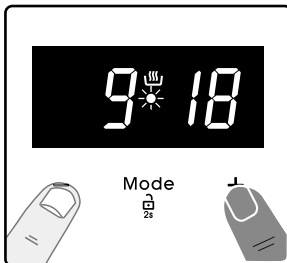

Press either [+] or [-] buttons to set the clock..

Step. 3

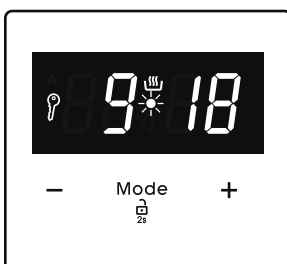

After a few seconds, the dot will stop flashing and will remain illuminated.

Key Lock

The key lock automatically activates after the timer has not been used for 7 seconds. " " symbol will appear and remain illuminated.

Step. 1

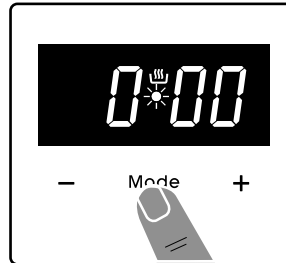

To unlock the timer buttons, press and hold the "MODE" button for 2 seconds. The desired operation can then be carried out.

Setting the minute minder

Step. 1

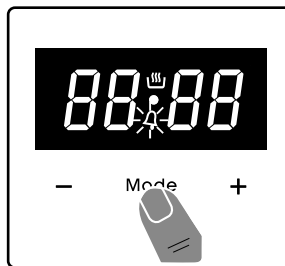

Note: The cook symbol remains visible during normal operation.

Step. 2

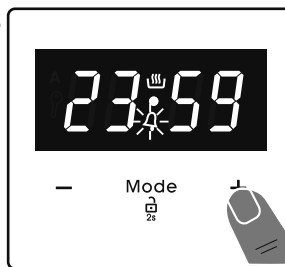

Press either [+] or [-] buttons to set the timer.

Step. 3

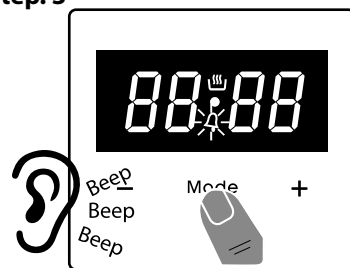

Once the specified time has elapsed an alarm will sound. To stop the alarm press the MODE button.

Setting the cooking duration *(main oven only)*

You have set the required temperature and function mode and you would like the oven to automatically stop. Note: The cook symbol [🔥] remains visible during normal operation.

Step. 1

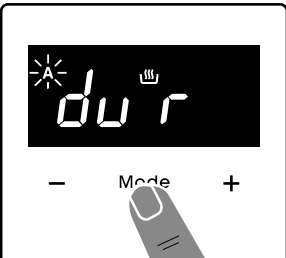

Press "MODE" until you see "dur" symbol on the display screen. The symbol "A" will flash.

Step. 2

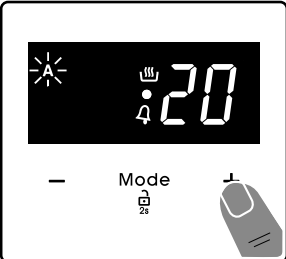

Set the cooking duration, for example add 20 minutes.

Step. 3

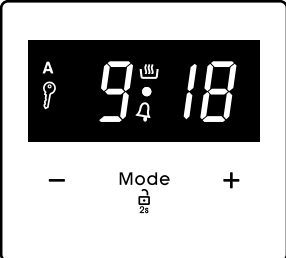

The current time will reappear on the screen, and the symbols "A", and "[🔥]" will remain illuminated.

Step. 4

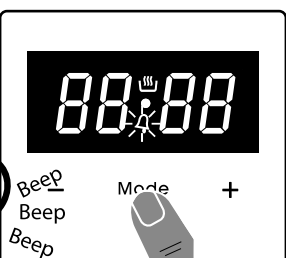

Once the specified time has elapsed an alarm will sound. To stop the alarm press the MODE button.

REMEMBER Turn the oven control knob (s) to 0.

Setting the finishing time *(main oven only)*

You have set the required temperature and function mode and you would like the oven to automatically **stop at a later time**. Note: The cook symbol [🔥] remains visible during normal operation.

Step. 1

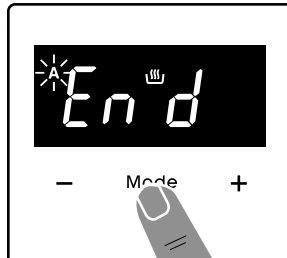

Press "MODE" until you see "End" symbol on the display screen. The symbol "A" will flash.

Step. 2



Press the "+" and "-" buttons to set the desired finishing time.

Step. 3

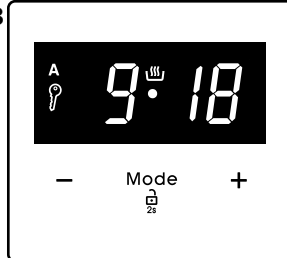

The current time will reappear on the screen, and the symbols "A", and "[🔥]" will remain illuminated.

Step. 4



Once the specified time has elapsed an alarm will sound. To stop the alarm press the MODE button.

REMEMBER Turn the oven control knob (s) to 0.

To start and stop the oven automatically

(main oven only)

You have set the required temperature and function mode and you would like the oven to automatically **stop at a later time**. **Note:** The cook symbol [☀] remains visible during normal operation.

Step. 1



Press "MODE" until you see "dur" symbol on the display screen.

The symbol "A" will flash.



Step. 2



Press the "+" and "-" buttons to set the desired finishing time.



Step. 3



Press "MODE" until you see "End" symbol on the display screen.

The symbol "A" will flash.



Step. 4



In this example the oven will come on automatically at 13.10 and switch off at 13.30am.



Step. 5

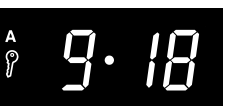

The current time will reappear on the screen, and the symbols "A", and will remain illuminated.



Step. 6





Once the specified time has elapsed an alarm will sound. To stop the alarm press the MODE button.





REMEMBER Turn the oven control knob (s) to 0.

Changing the frequency of the alarm



Step. 1



Step. 2



Step. 3

Step. 4

Step. 5

5. Cooking Tips

Tips on Cooking

If you want to cook more than one dish, choose dishes that require approximately the same cooking time. However, dishes can be 'slowed down' slightly by using small containers and covering them with aluminium foil, or 'speeded up' slightly by cooking smaller quantities or placing them in larger containers.

Very perishable foods such as pork or fish should be avoided if a long delay period is planned, especially in hot weather.

Whole poultry must be thoroughly defrosted before being placed in the oven. Check that meat and poultry are fully cooked before serving.

General Oven Tips

When you need to preheat the oven, we recommend you do so for ten minutes.

Ensure that food is placed centrally on the shelf and there is sufficient room around the baking tray/dish to allow for maximum circulation.

To reduce fat splashing when you add vegetables to hot fat around a roast, dry them thoroughly or brush lightly with cooking oil.

Where dishes may boil and spill over during cooking, place them on a baking tray.

If you want to brown the base of a pastry dish, preheat the baking tray for 15 minutes before placing the dish in the centre of the tray.

If you are cooking more than one tray of similar items, for example cakes, follow these simple steps to ensure even browning; swap the trays and rotate the food through 180° halfway through the cooking cycle. Also stagger the items on the shelves (Fig. 5.1).

Do not place baking trays directly onto the oven base, as it interferes with the air circulation and can lead to base burning; use the lower shelf position.

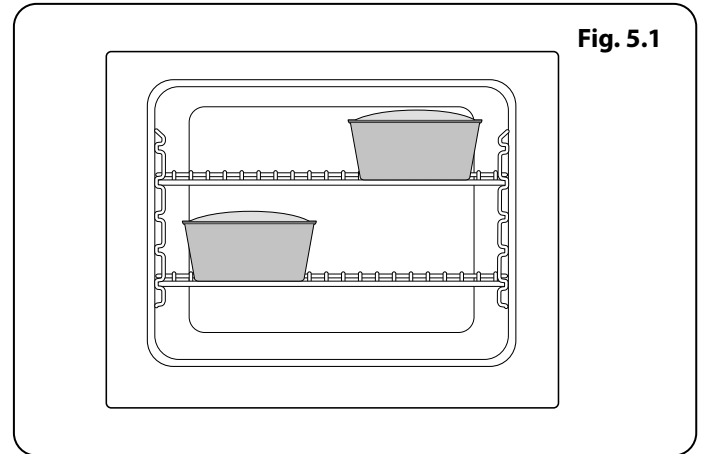

6. Cleaning Your Cooker

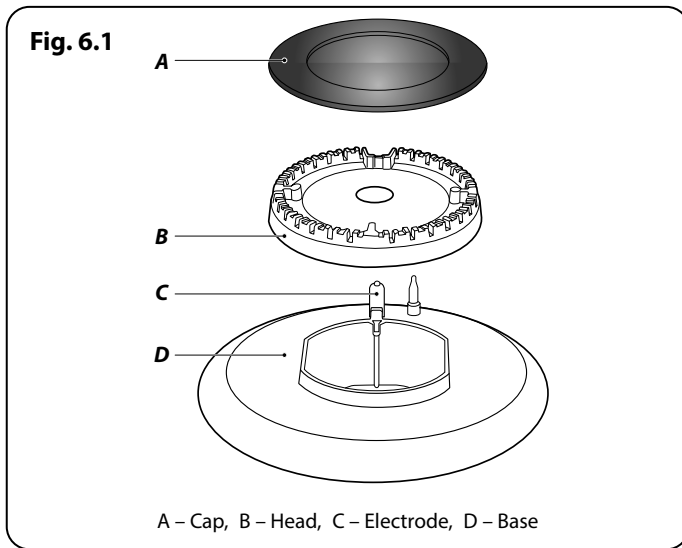

Isolate the electricity supply before carrying out any major cleaning. Allow the cooker to cool.

⚠ NEVER use paint solvents, washing soda, caustic cleaners, biological powders, bleach, chlorine based bleach cleaners, coarse abrasives or salt.

⚠ DO NOT mix different cleaning products – they may react together with hazardous results.

All parts of the cooker can be cleaned with hot soapy water – but take care that no surplus water seeps into the appliance.

Remember to switch on the electricity supply before re-using the cooker.

Hotplate Burners

The burner heads and caps can be removed for cleaning.

⚠ DO NOT put the burner heads in a dishwasher.

Make sure they are absolutely dry before replacing them.

- Remove the pan supports, caps and heads of the burners
- Wipe and clean the hotplate with warm soapy water.

Wash the caps and heads and rinse them. Do not leave them wet, immediately dry them with a kitchen towel.

After cleaning ensure they are re-assembled correctly (**Fig. 6.1**).

The Griddle

Always clean the griddle after use. Allow it to cool completely before removing. Immerse the griddle plate in hot soapy water. Use a soft cloth or, for stubborn stains, a nylon washing up brush.

Note: If the griddle is washed in a dishwasher then some dishwasher residue may appear on the back. This is normal and will not affect the performance of your griddle.

Grill

The grill pan can be easily removed for cleaning.

The grill pan and trivet should be washed in hot soapy water. After grilling meats or any foods that soil, leave to soak for a few minutes immediately after use. Stubborn particles may be removed from the trivet using a nylon brush. Alternatively, the grill pan can be washed in a dishwasher.

⚠ Before you remove any of the grill parts for cleaning, make sure that they are cool, or use oven gloves.

⚠ DO NOT use any abrasive substances.

Control Panel and Doors

Avoid using any abrasive cleaners, including cream cleaners. For best results, use a liquid detergent.

The same cleaner can also be used on the doors, or alternatively, using a soft cloth wrung out in clean hot soapy water. You can use the same method for cleaning the control panel and knobs.

After cleaning, polish with a dry cloth.

Oven Door Panel

The top oven door can be removed for ease of cleaning.

Open the oven door fully and release the saddle brackets situated either side (**Fig. 6.2**). Ensure that the saddle brackets are opened to their end positions, to prevent the hinges from retracting into the oven door.

Close the oven door until it is almost fully closed then carefully lift and un-hook the door panel from the cooker (**Fig. 6.3**).

To re-assemble, ensure that the saddle bracket and hinge mechanisms are correctly positioned (**Fig. 6.4**).

Carefully replace the door panel using the hinge locating notches, then close the saddle bracket (**Fig. 6.5**).

⚠ DO NOT use harsh abrasive cleaners or sharp metal scrapers to clean the oven door glass since they can scratch the surface, which may result in shattering of the glass.

Ovens

Cleaning the Inside of the Oven (Fig. 6.6)

- The inside of enamelled ovens are best cleaned while the oven is warm.
- Wipe the oven with a soft cloth soaked in soapy water after each use. Then, wipe the oven over again with a wet cloth and dry it.
- You may need to use a liquid cleaning material occasionally to completely clean the oven.

Catalytic Cleaning

Catalytic liners are installed within the oven cavity. These are the matte-finished, light-coloured panels on the sides and/or matte-finished panel at the rear of the oven. They work by collecting any grease and oil residue during cooking.

The liner self-cleans by absorbing fats and oils and burning them to ash, which can then be easily removed from the floor of the oven with a damp cloth. The lining must be porous to be effective. The liner may discolour with age.

If a large amount of fat is spilled onto the liner, it may reduce its efficiency. To overcome this problem, set the oven to maximum temperature for about 20 - 30 minutes. After the oven has cooled, wipe out the floor of the oven.

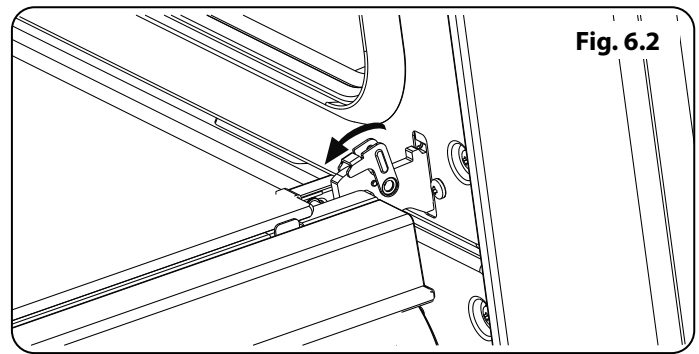

Fig. 6.2

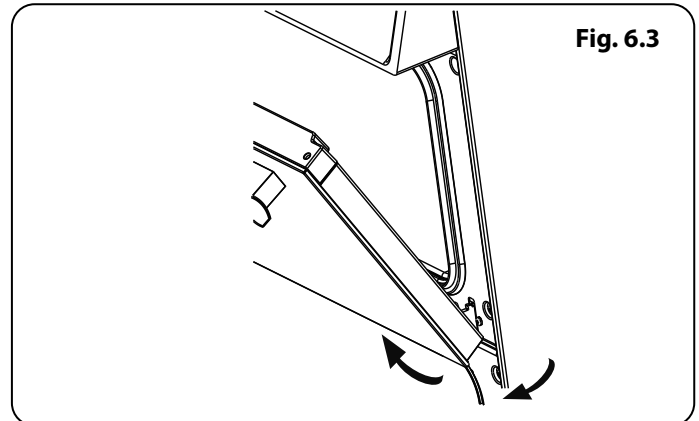

Fig. 6.3

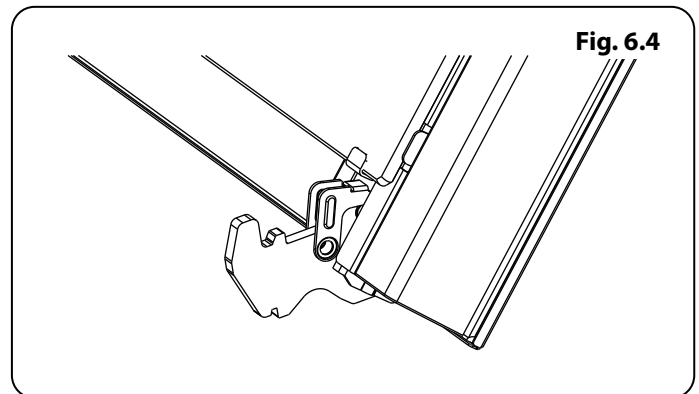

Fig. 6.4

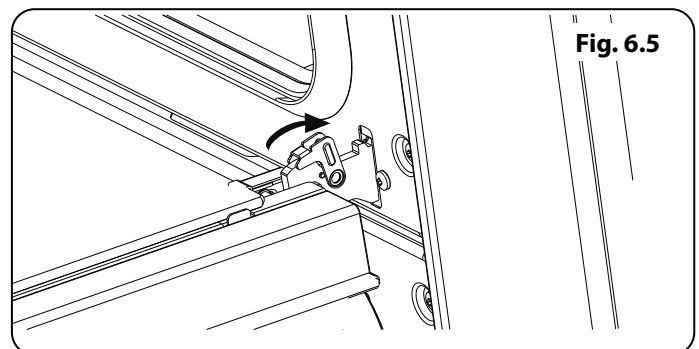

Fig. 6.5

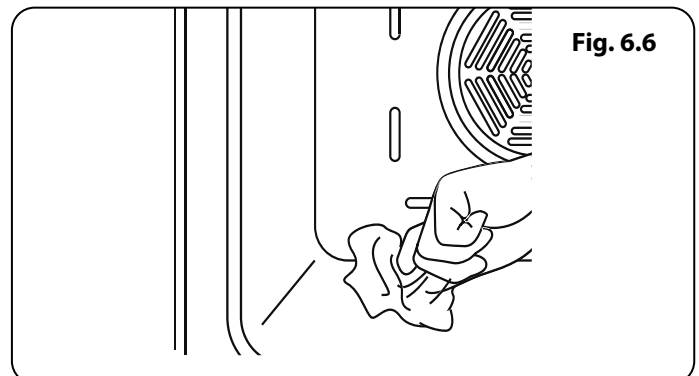
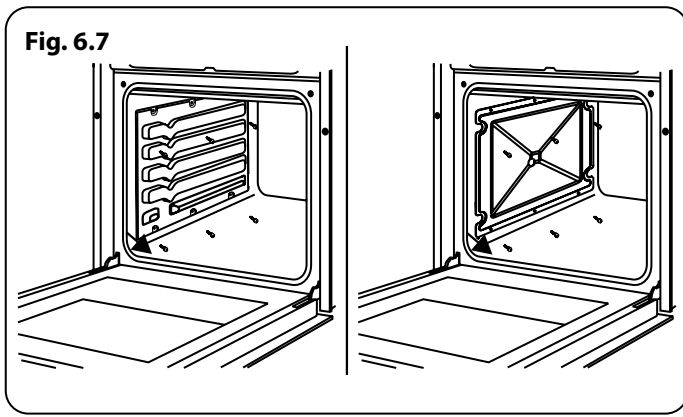

Fig. 6.6



Manual cleaning of the catalytic liners is not recommended. Damage will occur if a soap-impregnated steel wool pad or any other abrasives are used. In addition, we do not recommend the use of aerosol cleaners on the liners. The walls of a catalytic liner may become ineffective due to excess grease. The excess grease can be removed with a soft cloth or sponge soaked in hot water and the cleaning cycle can be carried out as described above.

Removal of the Catalytic Liner

To remove the catalytic liner, remove the screws holding each catalytic panel to the oven (**Fig. 6.7**).

Cleaning the Gas Hob

- Clean the gas hob on a regular basis.
- Take off the pan supports, caps and crowns of the hob burners.
- Wipe the hob surface with a soft cloth soaked in soapy water. Then, wipe the hob surface over again with a wet cloth and dry it.
- Wash and rinse the hob-burner caps. Do not leave them wet. Dry them immediately with a dry cloth.
- Make sure you re-assemble all parts correctly after cleaning.
- The surfaces of the pan supports may become scratched over time due to the use. This is not a production fault.

⚠ Do not use a metal sponge for cleaning any part of the hob.

⚠ Make sure no water gets into the burners as this may block the injectors.

Cleaning the Glass Parts

- Clean the glass parts of your appliance on a regular basis.
- Use a glass cleaner to clean the inside and outside of the glass parts. Then, rinse and dry them thoroughly with a dry cloth.

Cleaning the Enamelled Parts

- Clean the enamelled parts of your appliance on a regular basis.
- Wipe the enamelled parts with a soft cloth soaked in soapy water. Then, wipe them over again with a wet cloth and dry them.

⚠ Do not clean the enamelled parts while they are still hot from cooking.

⚠ Do not leave vinegar, coffee, milk, salt, water, lemon or tomato juice on the enamel for a long time.

Cleaning the Stainless Steel Parts

- Clean the stainless steel parts of your appliance on a regular basis.
- Wipe the stainless steel parts with a soft cloth soaked in only water. Then, dry them thoroughly with a dry cloth.

⚠ Do not clean the stainless steel parts while they are still hot from cooking.

⚠ Do not leave vinegar, coffee, milk, salt, water, lemon or tomato juice on the stainless steel for a long time.

Cleaning Painted Surfaces

Spots of tomato, tomato paste, ketchup, lemon, oil derivatives, milk, sugary foods, sugary drinks and coffee should be cleaned with a cloth dipped in warm water immediately. If these stains are not cleaned and allowed to dry on the surfaces they are on, they should NOT be rubbed with hard objects (pointed objects, steel and plastic scouring wires, surface-damaging dish sponge) or cleaning agents containing high levels of alcohol, stain removers, degreasers, surface abrasive chemicals. Otherwise, corrosion may occur on the powder painted surfaces, and stains may occur. The manufacturer will not be held responsible for any damage caused by the use of inappropriate cleaning products or methods.

Maintenance

⚠ WARNING: The maintenance of this appliance should be carried out by an authorised service person or qualified technician only.

Changing the Oven Lamp

⚠ WARNING: Switch off the appliance and allow it to cool before cleaning your appliance.

- Remove the glass lens, and then remove the bulb.
- Insert the new bulb (resistant to 300 °C) to replace the bulb that you removed (230 V, 15-25 Watt, Type E14).
- Replace the glass lens, and your oven is ready for use illumination..

Other Controls

- Periodically check expiration date of the gas connection pipe.
- Periodically check the gas connection pipe. If a defect is found, contact an authorised service provider to have it changed.
- If a defect is found while operating the control knobs of the appliance, contact an authorised service provider.

7. Troubleshooting

Problem	Possible Cause	Solution
Hob burners do not work.	<ul style="list-style-type: none"> The burners may be in the 'off' position. Supply gas pressure may not be correct. Power (if the appliance has an electric connection) is switched off. 	<ul style="list-style-type: none"> Check the position of the control knob. Check the gas supply and gas pressure. Check whether there is power supplied. Also check that other kitchen appliances are working.
Hob burners do not light.	<ul style="list-style-type: none"> Burner cap and crown are not assembled correctly. Supply gas pressure may not be correct. LPG cylinder (if applicable) may be depleted. Power (if the appliance has an electric connection) is switched off. 	<ul style="list-style-type: none"> Ensure the burner parts have been placed correctly. Check the gas supply and gas pressure. LPG cylinder may need replacing. Check whether there is power supplied. Also check that other kitchen appliances are working.
Flame colour is orange/yellow.	<ul style="list-style-type: none"> Burner cap and crown are not assembled correctly. Different gas compositions. 	<ul style="list-style-type: none"> Ensure the burner parts have been placed correctly. Due to the design of the burner, the flame can appear to be orange/yellow in certain areas of the burner. If you operate the appliance with natural gas, city natural gas may have different compositions. Do not operate the appliance for a couple of hours.
Burner is not igniting or only partially lighting.	<ul style="list-style-type: none"> Burner parts may not be clean or dry. 	<ul style="list-style-type: none"> Ensure that parts of the appliance are dry and clean.
Burner sounds noisy.	<ul style="list-style-type: none"> - 	<ul style="list-style-type: none"> This is normal. The noise may reduce as they heat up.
Noise		<ul style="list-style-type: none"> It is normal for some metal parts on the cooker to produce noise when in use.
The hob or cooking zones cannot be switched on.	<ul style="list-style-type: none"> There is no power supply. 	<ul style="list-style-type: none"> Check the household fuse for the appliance. Check whether there is a power cut by trying other electronic appliances.
The hob produces an odour during the first cooking sessions.	<ul style="list-style-type: none"> New appliance. 	<ul style="list-style-type: none"> Heat a saucepan full of water on each cooking zone for 30 minutes.
Oven does not turn on.	<ul style="list-style-type: none"> Power is turned off. 	<ul style="list-style-type: none"> Check whether there is power supplied. Also check that other kitchen appliances are working.
No heat or oven does not warm up.	<ul style="list-style-type: none"> Oven temperature control is incorrectly set. Oven door has been left open. 	<ul style="list-style-type: none"> Check the oven temperature control knob is set correctly.

Problem	Possible Cause	Solution
Cooking is uneven within the oven.	<ul style="list-style-type: none"> Oven shelves are incorrectly positioned. 	<ul style="list-style-type: none"> Check that the recommended temperatures and shelf positions are being used. Do not frequently open the door unless you are cooking things that need to be turned. If you open the door often, the interior temperature will be lower and this may affect the results of your cooking.
Oven light (if available) does not operate.	<ul style="list-style-type: none"> Lamp has failed. Electrical supply is disconnected or switched off. 	<ul style="list-style-type: none"> Replace lamp according to the instructions. Make sure the electrical supply is switched on at the wall socket outlet.
The timer buttons cannot be pressed properly.	<ul style="list-style-type: none"> There is foreign matter caught between the timer buttons. Touch model: there is moisture on the control panel. The key lock function is set. 	<ul style="list-style-type: none"> Remove the foreign matter and try again. Remove the moisture and try again. Check whether the key lock function is set.
The oven fan (if available) is noisy.	<ul style="list-style-type: none"> Oven shelves are vibrating. 	<ul style="list-style-type: none"> Check that the oven is level. Check that the shelves and any bake ware are not vibrating or in contact with the oven back panel.
Cooling fan (if available) isn't working	<ul style="list-style-type: none"> Electrical supply is disconnected or switched off. 	<ul style="list-style-type: none"> Make sure the electrical supply is switched on at the wall socket outlet.

Transport

If you need to transport the product, use the original product packaging and carry it using its original case. Follow the transport signs on the packaging. Tape all independent parts to the product to prevent damaging the product during transport.

If you do not have the original packaging, prepare a carriage box so that the appliance, especially the external surfaces of the product, is protected against external threats.

INSTALLATION

Check the appliance is electrically safe and gas sound when you have finished.

8. Installation

Dear Installer

Before you start your installation, please complete the details below, so that, if your customer has a problem relating to your installation, they will be able to contact you easily.

Installer's Name
Installer's Company
Installer's Telephone Number
Appliance Serial Number

Safety Requirements and Regulations

- ⚠ WARNING :** This appliance must be installed by an authorised service person or qualified technician, according to the instructions in this guide and in compliance with the current local regulations.
- ⚠ Incorrect installation may cause harm and damage, for which the manufacturer accepts no responsibility and the warranty will not be valid.**
- ⚠ Prior to installation, ensure that the local distribution conditions (electricity voltage and frequency and/or nature of the gas and gas pressure) and the adjustments of the appliance are compatible. The adjustment conditions for this appliance are stated on the label.**
- ⚠ The laws, ordinances, directives and standards in force in the country of use are to be followed (safety regulations, proper recycling in accordance with the regulations, etc.).**

Instructions for the Installer Ventilation requirements

For rooms with a volume of less than 5 m³, permanent ventilation of 100 cm² free area is required.

For rooms with a volume of between 5 m³ and 10 m³, permanent ventilation of 50 cm² free area will be required, unless the room has a door which opens directly to outside air in which case no permanent ventilation is required.

For rooms with a volume greater than 10 m³, no permanent ventilation is required.

Important: Regardless of room size, all rooms containing the appliance must have direct access to outside air via an openable window or equivalent.

Emptying of burned gases from the environment

Gas appliances expel burned gas waste to the outside air, either directly or via a cooker hood with a chimney. If it is not possible to install a cooker hood, install a fan on the window or wall that has access to fresh air. The fan must have the capacity to change the volume of air in the kitchen a minimum of 4-5 times per hour.

Location of Cooker

The cooker may be installed in a kitchen/kitchen diner but **NOT** in a room containing a bath or shower.

This appliance is designed for domestic cooking only. Use for any other purpose could invalidate any warranty or liability claim.

Note: An appliance for use on LPG must not be installed in a room or internal space below ground level, e.g. in a basement.

INSTALLATION

Check the appliance is electrically safe and gas sound when you have finished.

Positioning the Cooker

Fig. 8.2 shows the minimum recommended distance from the cooker to nearby surfaces.

The cooker should not be placed near the fridge or on a base.

The hotplate surround should be level with, or above, any adjacent work surface.

The cooker is designed to fit between kitchen cabinets spaced over 600 mm apart. 5 mm clearance either side of the appliance is recommended to allow removal of the cooker for servicing.

A minimum space of 700 mm is required between the top of the hob and a horizontal combustible surface. This can be reduced to 650 mm if a cookerhood is installed.

*Any cookerhood should be installed in accordance with the hood manufacturer's instructions.

**Any splashback must be fitted in accordance with the manufacturers instructions.

It is recommended that there is at least 20 mm space between the back cover of the cooker and the wall, for air circulation (**Fig. 8.3**).

Adjacent kitchen furniture must be heat resistant to 90°C.

General instructions

After removing the packaging material from the appliance and its accessories, ensure that the appliance is not damaged. If you suspect any damage, do not use it and contact an authorised service person or qualified technician immediately.

Make sure that there are no flammable or combustible materials in the close vicinity, such as curtains, oil, cloth etc. which may catch fire.

The worktop and furniture surrounding the appliance must be made of materials resistant to temperatures above 100°C.

The appliance should not be installed directly above a dishwasher, fridge, freezer, washing machine or clothes dryer.

The appliance can be placed close to other furniture on condition that, in the area where the appliance is set up, the furniture's height does not exceed the height of the cooktop.

Installation of the Cooker

If the kitchen furniture is higher than the cooktop, the kitchen furniture must be at least 10 cm away from the sides of appliance for air circulation.

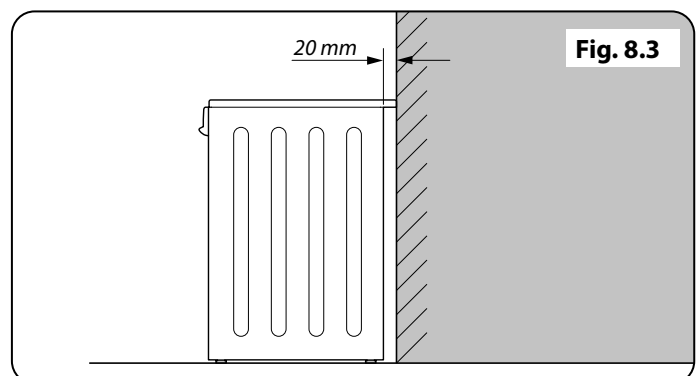
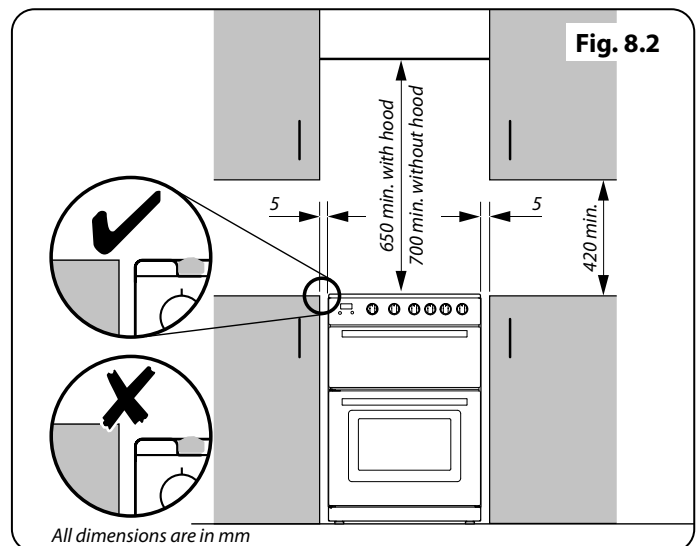
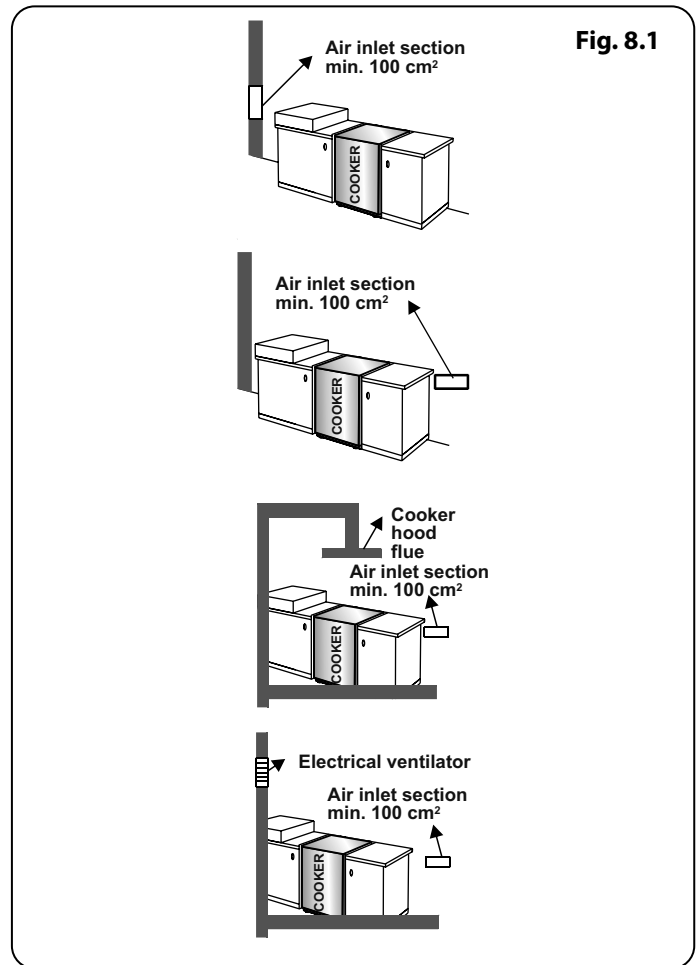

INSTALLATION

Check the appliance is electrically safe and gas sound when you have finished.

Fig. 8.4

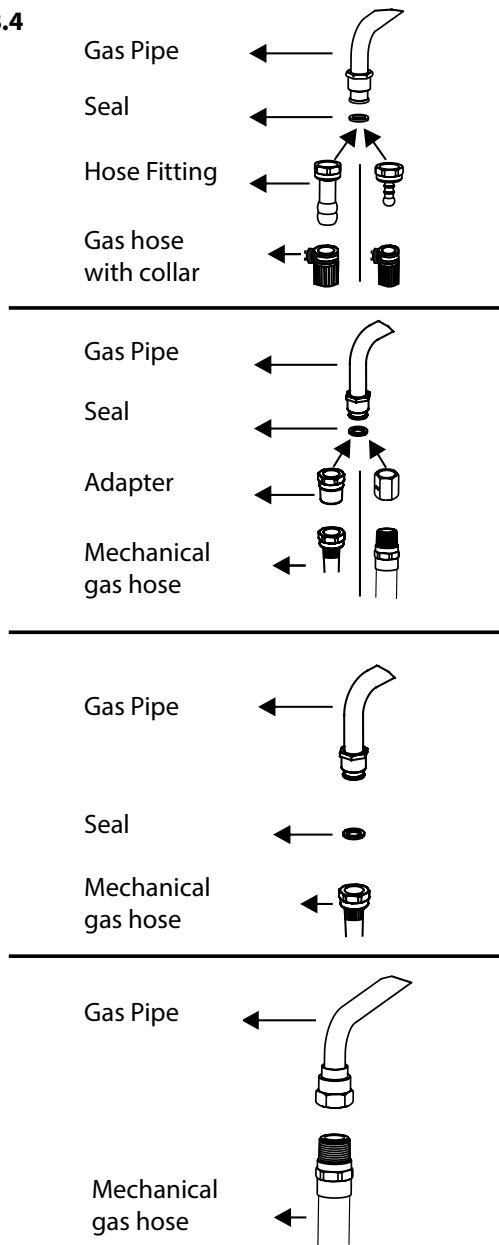

Moving the Cooker

- ⚠ **On no account try and move the cooker while it is plugged into the electricity supply.**
- ⚠ **The cooker is very heavy, so take great care.**
- ⚠ **Do not try to lift or move the cooker by pulling on the door handles.**

We recommend that two people manoeuvre the cooker. Make sure that the floor covering is firmly fixed, or removed, to prevent it being disturbed when moving the cooker around.

Assembly of gas supply and leakage check

Connect the appliance in accordance with applicable local and international standards and regulations. First, check what type of gas is installed on the cooker.

This information is available on a sticker on the back of the cooker. You can find the information related to appropriate gas types and appropriate gas injectors in the technical data table. Check that the feeding gas pressure matches the values on the technical data table, to be able to get the most efficient use and to ensure the minimum gas consumption. If the pressure of used gas is different than the values stated or is not stable in your area, it may be necessary to assemble an available pressure regulator on the gas inlet. You should contact an authorised service centre to make these adjustments.

Points that must be checked during flexible hose assembly:

If the gas connection is made by a flexible hose fixed onto the gas inlet of the hob, it must be fixed on by a pipe collar.

Connect your appliance with a short and durable hose that is as close as possible to the gas source.

The permitted maximum length of the hose is 1.5 m.

The device should be connected in line with the relevant local gas standards.

The hose must be kept clear of areas that may heat up to temperatures of more than 90°C.

The hose must not be cracked, torn, bent or folded.

Keep the hose clear of sharp corners and objects that could move.

Before you assemble the connection, you must make sure the hose is not damaged. Use bubbly water or leakage fluids to perform the check. Do not use a naked flame to check for gas leakage.

All metal items that are used during gas connection must be free from rust. Check the expiry date of any components used for connection.

INSTALLATION

Check the appliance is electrically safe and gas sound when you have finished.

Points that must be checked during fixed gas connection assembly

The method used to assemble a fixed gas connection (gas connection made by threads, e.g. a nut) varies according to the country you are in. The most common parts for your country will be supplied with your appliance. Any other parts required can be supplied as spare parts.

During connection, always keep the nut on the gas manifold fixed while rotating the counter-part. Use appropriately-sized spanners for a safe connection. For surfaces between different components always use the seals provided in the gas conversion kit.

The seals used during connection should also be approved to be used in gas connections. Do not use plumbing seals for gas connections.

Remember that this appliance is ready to be connected to the gas supply in the country for which it has been produced.

The main country of destination is marked on the rear cover of the appliance. If you need to use it in another country, any of the connections in the figure below may be required. In such a case, contact local authorities to learn the correct gas connection.

The Cooker must be installed and maintained by a suitably qualified gas registered technician in accordance with current safety legislation.

⚠ WARNING: Do not use a naked flame to check for gas leaks.

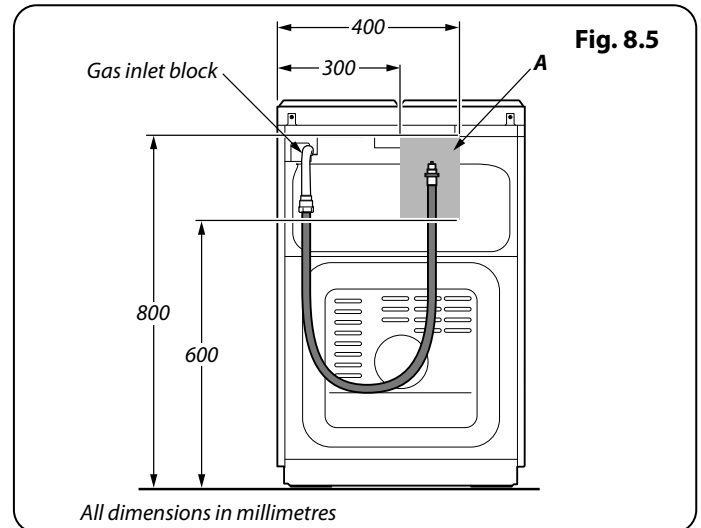

INSTALLATION

Check the appliance is electrically safe and gas sound when you have finished.

Current Operated Earth Leakage Breakers

The combined use of your cooker and other domestic appliances may cause nuisance tripping, so we recommend that the cooker is protected on an individual RCD (Residual Current Device) or RCBO (Residual Current Breaker with Overload).

If in doubt, please consult a suitably qualified electrician.

Fig. 8.6

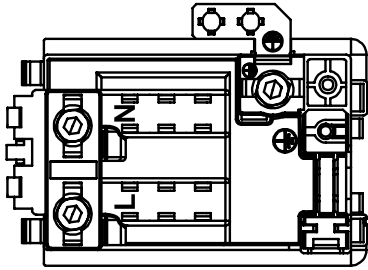

Fig. 8.7

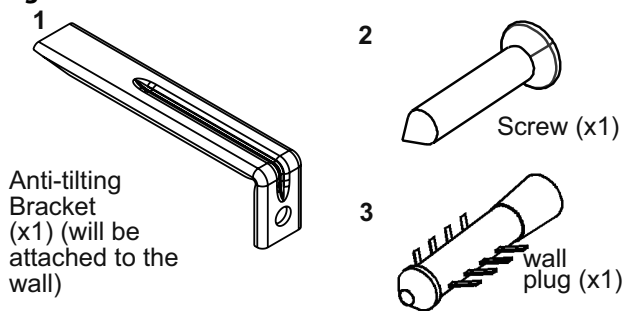
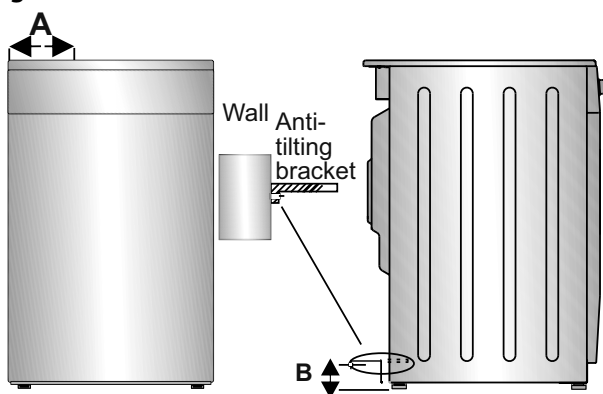

Fig. 8.8



Electrical Connection

All external wiring must comply with the IEE Regulations for the Electrical Equipment of Buildings. Connection to the electrical supply is via a plug and socket.

⚠ WARNING: The electrical connection of this appliance should be carried out by an authorised service person or qualified electrician, according to the instructions in this guide and in compliance with the current local regulations.

⚠ WARNING: THE APPLIANCE MUST BE EARTHED.

Refer to Fig. 8.6 for electrical connections

- Before connecting the appliance to the power supply, the voltage rating of the appliance (stamped on the appliance identification plate) must be checked for correspondence to the available mains supply voltage, and the mains electric wiring should be capable of handling the appliance's power rating (also indicated on the identification plate).
- During installation, please ensure that isolated cables are used. An incorrect connection could damage your appliance. If the mains cable is damaged and needs to be replaced this should be done by a qualified person.
- Do not use adaptors, multiple sockets and/or extension leads.
- The supply cord should be kept away from hot parts of the appliance and must not be bent or compressed. Otherwise the cord may be damaged, causing a short circuit.
- If the appliance is not connected to the mains with a plug, a all-pole disconnector (with at least 3 mm contact spacing) must be used in order to meet the safety regulations.
- The appliance is designed for a power supply of 220-240 V~. If your supply is different, contact the authorized service personnel or qualified electrician.
- The power cable must be long enough to be connected to the appliance.
- The fused switch must be easily accessible once the appliance has been installed.
- Ensure all connections are adequately tightened.
- Fix the supply cable in the cable clamp and then close the cover.
- The terminal box connection is placed on the terminal box.

INSTALLATION

Check the appliance is electrically safe and gas sound when you have finished.

⚠ IMPORTANT: The wires in the mains lead are coloured in accordance with the following code (Fig. 8.6):

- Green/Yellow (Earth) wire to the terminal marked "PE".
- Brown (Live) wire to the terminal marked "L".
- Blue (Neutral) wire to the terminal marked "N".

⚠ The installer should be responsible for selecting the correct cable rating for this appliance.

Anti-tilting kit

The document bag (Fig. 8.7) contains an anti-tilting kit. Loosely attach the antitilting bracket (1) to the wall using the screw (2) and wall plug (3), following the measurements shown in the figure and table below. Adjust the height of the antitilting bracket so that it lines up with the slot on the cooker and tighten the screw. Push the appliance towards the wall making sure that the anti-tilting bracket is inserted into the slot on the rear of the appliance (Fig. 8.8).

Adjusting the feet

Your product stands on four adjustable feet (Fig. 8.9). For safe operation, it is important that your appliance is correctly balanced. Make sure the appliance is level prior to cooking.

To increase the height of the appliance, turn the feet anti-clockwise. To decrease the height of the appliance, turn the feet clockwise.

It is possible to raise the height of the appliance up to 30 mm by adjusting the feet. The appliance is heavy and we recommend that a minimum of 2 people lift it. Never drag the appliance.

Final Checks

Hotplate Check

Check each burner in turn (refer to the 'Hotplate Burners' section at the front of the instructions).

Grill Check

Turn on the grill and check that the grill heats up.

Oven Check

Turn on the ovens. Check that the burners light and the ovens heat up.

Customer Care

Installer: Please complete your details in this guide, inform the user how to operate the cooker and hand over the instructions.

Thank you.

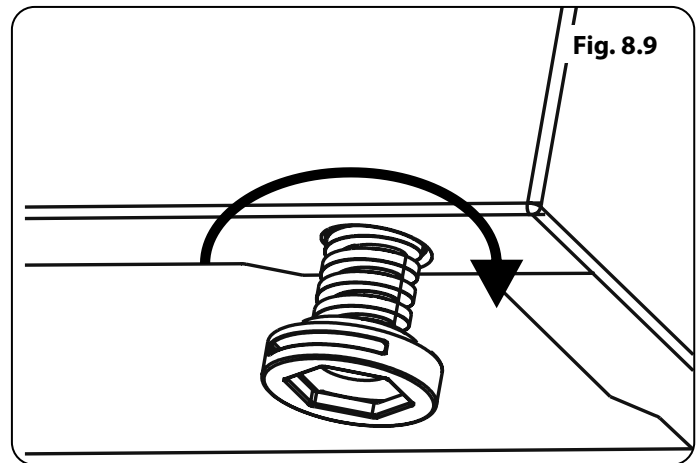

WARNING – SERVICING TO BE CARRIED OUT ONLY BY AN AUTHORISED PERSON
Disconnect from electricity and gas before servicing. Check appliance is safe when you have finished.

9. Conversion to LP Gas

Fig. 9.1

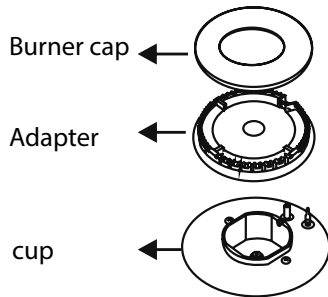

Fig. 9.2

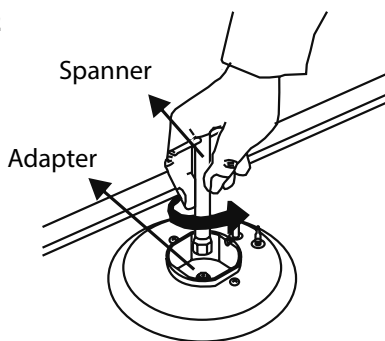
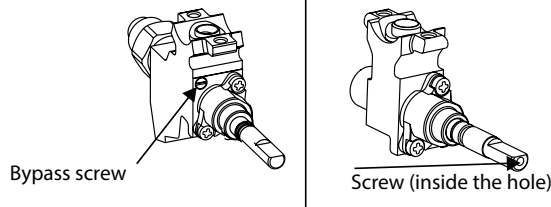

Fig. 9.3

Valve with flame failure device

Valve without flame failure device



Check the 'Technical Data' section at the back of the book that the hob is convertible to the gas you want to use.

Your appliance is designed to be operated with LPG/NG gas. The gas burners can be adapted to different types of gas, by replacing the corresponding injectors and adjusting the minimum flame length suitable to the gas in use. For this purpose, the following steps should be performed.

- ⚠ Failure to convert the appliance correctly could invalidate any warranty or liability claims and lead to prosecution.**
- ⚠ When servicing or replacing gas-carrying components disconnect from the gas supply before starting operation. Check the appliance is gas sound after completion.**
- ⚠ DO NOT use reconditioned or unauthorised gas controls.**
- ⚠ Disconnect from the electricity supply before servicing.**
- ⚠ Before electrical reconnection, check that the appliance is electrically safe.**

Changing injectors

Hob burners

Cut off the main gas supply and unplug the appliance from the mains electrical supply.

- Remove the burner caps and the adapters (**Fig. 9.1**).
- Use a 7 mm spanner to unscrew the injectors (**Fig. 9.2**).
- Replace the injector with the ones from the gas conversion kit, with the correct diameters for the type of gas that is going to be used, according to the gas injector table.

Adjusting the minimum flame position

First of all, make sure that the appliance is unplugged from the mains electrical supply and that the gas feed is open. The minimum flame position is adjusted with a flat screw located on the valve. As shown in the figures; for valves with a flame failure safety device, the screw is located on the side of the valve spindle and for valves without a flame failure safety device, the screw is located inside the valve spindle. To make adjusting the flame position easier, we recommend that you remove the control panel (and the micro switch if your model has one) during the alteration. The bypass screw must be loosened for conversion from LPG to natural gas. For conversion from natural gas to LPG, the bypass screw must be tightened.

WARNING – SERVICING TO BE CARRIED OUT ONLY BY AN AUTHORISED PERSON
Disconnect from electricity and gas before servicing. Check appliance is safe when you have finished.

Determining the minimum flame position

To determine the minimum position, ignite the burners and leave them on in the minimum position. Remove the knobs to gain access to the screws. With the help of a small screwdriver, fasten or loosen the bypass screw by around 90 degrees. When the flame has a length of at least 4mm, the gas is well distributed. Make sure that the flame does not die out when passing from the maximum position to the minimum position. Create an artificial wind with your hand towards the flame to see if the flames are stable. For the oven burner, operate the oven burner at the minimum position for 5 minutes, then open and close the oven door 2-3 times to check the flame stability of the burner.

Changing the gas inlet

For some countries, the gas inlet type can be different for NG/LPG gases. In this case, remove the current connection components and nuts (if any) and connect the new gas supply accordingly. In all conditions, all components used in gas connections should be approved by local and/or international authorities. In all gas connections, refer to the "Assembly of gas supply and leakage check".

Pressure Testing

Connect the appliance to the gas supply. Check the appliance is gas sound.

The gas pressure can be measured at one of the hotplate injectors. Lift off a burner head. Fit the pressure gauge to the jet. Turn on and light one of the other burners with a match. Turn on and press in the control knob for the burner with the pressure gauge fitted.

The pressure should be 29 mbar for Butane and 37 mbar for Propane.

After checking the pressure, turn off the taps and replace the burner head.

Reassemble burner top, making sure it is reassembled in the correct way on the burner body.

 **Check the appliance is gas sound.**

 **Check operation of all the burners.**

Assembly of gas supply and leakage check

Connect the appliance in accordance with applicable local and international standards and regulations. First, check what type of gas is installed on the cooker.

This information is available on a sticker on the back of the cooker. You can find the information related to appropriate gas types and appropriate gas injectors in the technical data table. Check that the feeding gas pressure matches the values on the technical data table, to be able to get the most efficient use and to ensure the minimum gas consumption. If the pressure of used gas is different than the values stated or is not stable in your area, it may be necessary to assemble an available pressure regulator on the gas inlet. You should contact an authorised service centre to make these adjustments.

10. Circuit Diagram

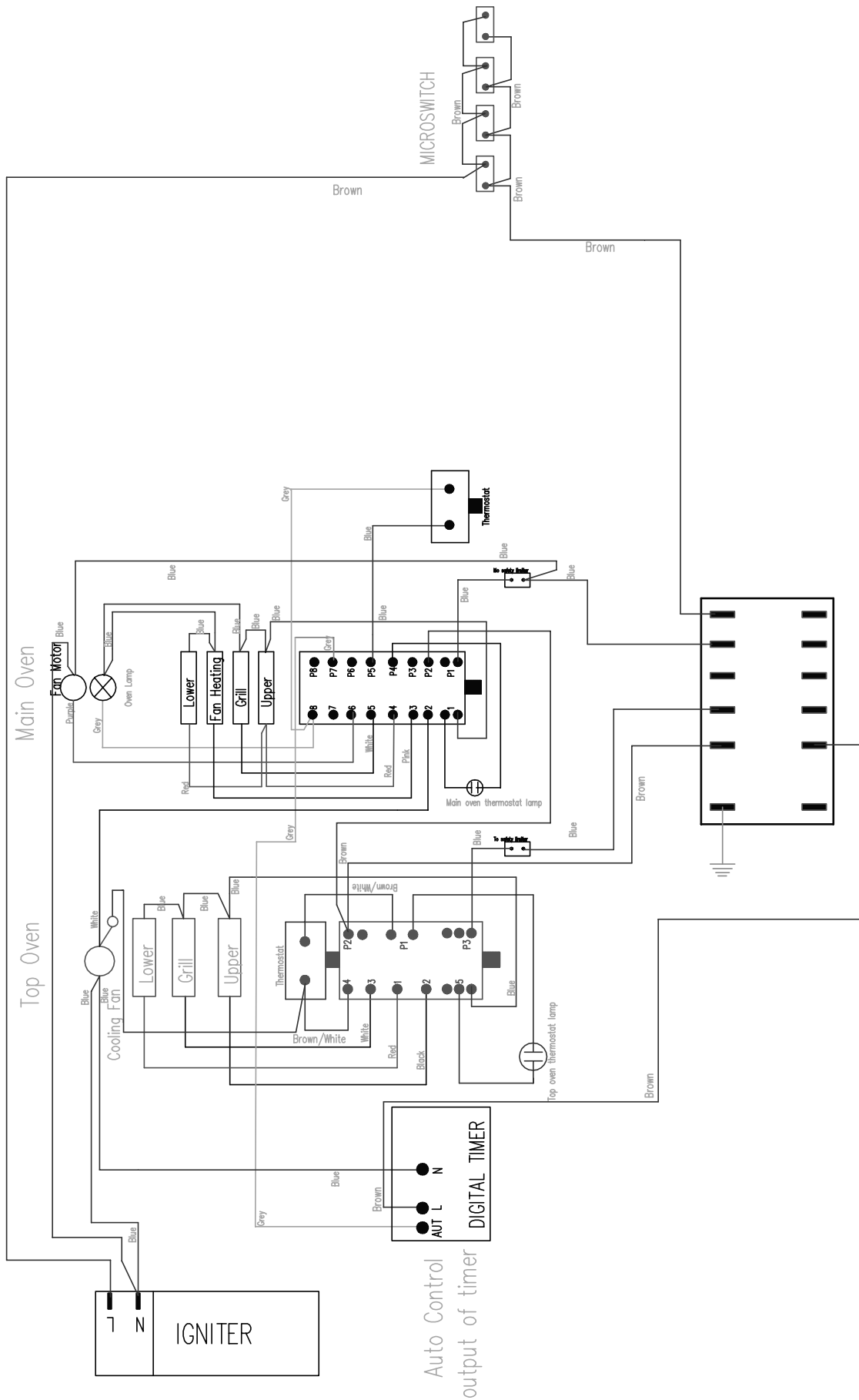

11. Technical Data

This cooker is designed for use on either:

- Natural gas (Cat I_{2H}) at 20 mbar or
- LP gas (Cat I₃₊) Butane 29 mbar / Propane 37 mbar

INSTALLER: Please leave these instructions with the user.

DATA BADGE LOCATION: Cooker back, serial number repeater badge below oven door opening.

COUNTRY OF DESTINATION: GB, IE.

Connections See the appliance badge for test pressures.

Gas (Rp ½ at rear right-hand side)		Electric
Natural gas	20 mbar	230 / 400V 50 Hz
Butane	29 mbar	
Propane	37 mbar	

Dimensions

Overall height	minimum 895 mm	maximum 925 mm
Overall width	600 mm	
Overall depth	600 mm (to fascia inc. splashback); 610 mm (over hotplate)	
Minimum space above hotplate	700 mm / 650 mm with cooker hood	

Refer to 'Positioning the Cooker'.

Ratings

Hotplate	Natural Gas 20 mb		L.P. Gas	
		Injector		Injector
Rapid burner	2.9 kW	115	3.0 kW (218.1 g/h)	85
Medium burner	1.75 kW	97	1.75 kW (127.2 g/h)	65
Small burner	1.0 kW	72	1.0 kW (72.7 g/h)	50

Consumption is based on G30.

Trademark	Rangemaster
Models	CLA60DFFBL/C, CLA60DFFCR/C PROPL60DFFSS/C, PROPL60DFFBL/C
Type of Hob	Gas
Number of Cooking Zones	4
Heating Technology-1	Gas
Size-1	Auxiliary
Energy Efficiency-1	N/A
Heating Technology-2	Gas
Size-2	Semi-Rapid
Energy Efficiency-2	59 %
Heating Technology-3	Gas
Size-3	Semi-Rapid
Energy Efficiency-3	59 %
Heating Technology-4	Gas
Size-4	Rapid Burner
Energy Efficiency-4	57 %
Energy Efficiency of Hob	58.3 %
This hob complies with EN 30-2-1	

Energy saving tips

- Use cookware with a flat base.
- Use the correct size cookware.
- Use cookware with a lid.
- Minimise the amount of liquid or fat.
- When liquid starts boiling, reduce the setting.

Oven Efficiency

	Trademark		Rangemaster
	Models		CLA60DFFBL/C CLA60DFFCR/C PROPL60DFFSS/C PROPL60DFFBL/C
	Type of Oven		Electric
	Mass	kg	47
	Number of cavities		2
Upper cavity	Heat source		Electric
	Volume	Litres	39
	Energy consumption (electricity) - conventional	kWh / cycle	0.75
	Energy consumption (electricity) - forced air convection	kWh / cycle	-
	Energy Efficiency Index - conventional		105.1
	Energy Efficiency Index - forced air convection		-
	Energy Class		A
Lower cavity	Heat source		Electric
	Volume	Litres	69
	Energy consumption (electricity) - conventional	kWh / cycle	0.87
	Energy consumption (electricity) - forced air convection	kWh / cycle	0.79
	Energy Efficiency Index - conventional		103.6
	Energy Efficiency Index - forced air convection		94.1
	Energy Class		A
	This oven complies with EN 15181		

Energy saving tips

- Cook meals together, if possible.
- Keep the pre-heating time short.
- Do not lengthen cooking time.
- Do not forget to turn the appliance off at the end of cooking.
- Do not open the oven door during the cooking period.
- Consumption is based on G30.

Maximum total electrical load at 230 V (approximate total including oven lights, oven fan, etc.) 4.6 kW

AGA RANGEmaster

Clarence Street, Royal Leamington Spa,
Warwickshire, CV31 2AD, England.

Tel: +44 (0) 1926 457400 Fax: +44 (0) 1926 450526

E-mail: consumers@rangemaster.co.uk